

Class 125 Iron Body Wedge Gate

Bolted Bonnet Non-Rising Stem Solid Wedge Bronze Trim or All Iron Trim

From 2" to 12"

125 P S I 450 F
200 WOG -20 to 150 F

From 14" to 24"

100 P S I 450 F
150 WOG -20 to 150 F

Applicable Standards: MSS-SP-70, ANSI B16.1, ANSI B16.10

PARTS AND MATERIAL DESCRIPTION

No.	Part	Material	ASTM Spec.
1	Handwheel Nut	Steel	ASTM A307
2	Handwheel	Cast Iron	ASTM A126 CI B
3	Packing Gland	Cast Iron	ASTM A126 CI B
4	Packing	Non-Asbestos	Commercial
5	Stem (5)	Forging Brass	ASTM B16
	Stem (28)	Steel 12L14	ASTM A108
6	Gland Bolt	Steel	ASTM A307
7	Gland Nut	Steel	ASTM A307
8	Bonnet Bolt & Nut	Steel	ASTM A307
9	Bonnet	Cast Iron	ASTM A126 CI B
10	Bonnet Gasket	Non-Asbestos	Commercial
11	Body	Cast Iron	ASTM A126 CI B
12	Wedge	Cast Iron	ASTM A126 CI B
13	Seat Ring (5)	Cast Bronze	ASTM B62
	Seat Ring (28)	Cast Iron	ASTM A126 CI B
14	Wedge Ring (5)	Cast Bronze	ASTM B62

* All iron trim: 125-B-28

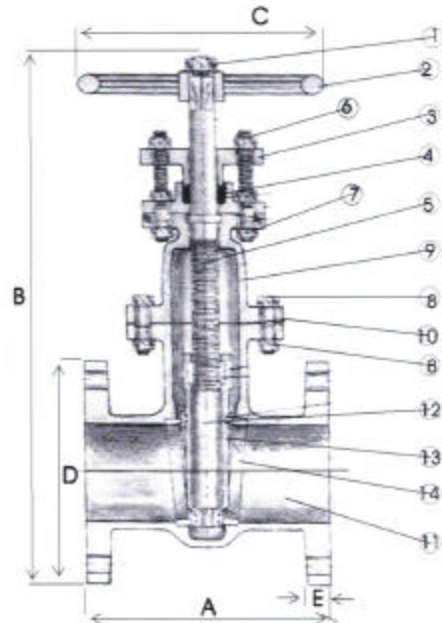

Nominal Size	Dimensions					Approx. Weight
	A	B	C	D	E	
2"	7"	14"	7"	6"	5/8"	40
2.5"	7 1/2"	15"	7 1/2"	7 1/2"	11/16"	57
3"	8"	18"	9"	7 1/2"	3/4"	70
4"	9"	22 3/4"	10"	9"	15/16"	96
5"	10"	25 1/4"	12"	10"	15/16"	154
6"	10 1/2"	31"	12"	11"	1"	195
8"	11 1/2"	33"	16"	13 1/2"	1 1/8"	290
10"	13"	41 1/4"	18"	16"	1 3/16"	435
12"	14"	45 1/2"	20"	19"	1 1/4"	543
14"	15"	50"	20"	21"	1 3/8"	616
16"	16"	51"	22"	23 1/2"	1 7/16"	700
18"	17"	54"	22"	25"	1 9/16"	990
20"	18"	62 1/2"	23 1/2"	27 1/2"	1 11/16"	1221
24"	20"	66"	30"	32"	1 15/16"	1914