

# STEAMCO

Fig. 250-B

## Class 250 Iron Body Wedge Gate

Bolted Bonnet Non-Rising Stem Solid Wedge Bronze Trim or All Iron Trim

From 2" to 8"

250 P S I      450 F

500 WOG      -20 to 150 F

Applicable Standards: MSS-SP-70, ANSI B16.1, ANSI B16.10

### PARTS AND MATERIAL DESCRIPTION

No.	Part	Material	ASTM Spec.
1	Handwheel Nut	Steel	ASTM A307
2	Handwheel	Cast Iron	ASTM A126 CI B
3	Packing Gland	Cast Iron	ASTM A126 CI B
4	Packing	Non-Asbestos	Commercial
5	Stem ( 5 )	Forging Brass	ASTM B16
	Stem ( 28 )	Steel 12L14	ASTM A108
6	Gland Bolt	Steel	ASTM A307
7	Gland Nut	Steel	ASTM A307
8	Bonnet Bolt & Nut	Steel	ASTM A307
9	Bonnet	Cast Iron	ASTM A126 CI B
10	Bonnet Gasket	Non-Asbestos	Commercial
11	Body	Cast Iron	ASTM A126 CI B
12	Wedge	Cast Iron	ASTM A126 CI B
13	Seat Ring ( 5 )	Cast Bronze	ASTM B62
	Seat Ring ( 28 )	Cast Iron	ASTM A126 CI B
14	Wedge Ring ( 5 )	Cast Bronze	ASTM B62

\* All iron trim: 250-B-28

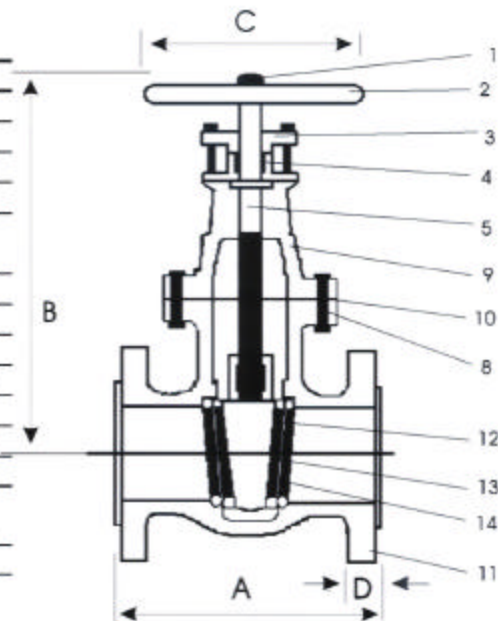

Nominal Size	Dimensions				Aprox. Weight
	A	B	C	D	
2"	8 1/2"	12 1/2"	7"	7/8"	59
2.5"	9 1/2"	15"	8"	1"	75
3"	11 1/8"	16 1/2"	10"	1 1/8"	102
4"	12"	18 1/2"	12"	1 1/4"	170
5"	15"	20 3/4"	12"	1 3/8"	217
6"	15 7/8"	24"	16"	1 7/16"	295
8"	16 1/2"	28 1/2"	16"	1 5/8"	430