

STEAMCO

Fig. 250-A

Class 250 Iron Body Wedge Gate

Bolted Bonnet OS&Y Solid Wedge Bronze Trim or All Iron Trim

From 2" to 12"

250 P S I 450 F

500 WOG -20 to 150 F

Applicable Standards: MSS-SP-70, ANSI B16.1, ANSI B16.10

PARTS AND MATERIAL DESCRIPTION

No.	Part	Material	ASTM Spec.
1	Handwheel Nut	Cast Bronze	ASTM B62
2	Handwheel	Cast Iron	ASTM A126 Cl B
3	Yoke Nut	Cast Bronze	ASTM B62
4	Yoke	Cast Iron	ASTM A126 Cl B
5	Stem (5)	Forging Brass	ASTM B16
	Stem (28)	Steel 12L14	ASTM A108
6	Eye Bolt	Steel	ASTM A307
7	Packing	Non-Asbestos	Commercial
8	Bonnet Bolt	Steel	ASTM A307
9	Bonnet Bolt Nut	Steel	ASTM A307
10	Bonnet Gasket	Non-Asbestos	Commercial
11	Body	Cast Iron	ASTM A126 Cl B
12	Wedge	Cast Iron	ASTM A126 Cl B
13	Seat Ring (5)	Cast Bronze	ASTM B62
	Seat Ring (28)	Cast Iron	ASTM A126 Cl B
14	Wedge Ring (5)	Cast Bronze	ASTM B62
	Wedge Ring (28)	Cast Iron	ASTM A126 Cl B

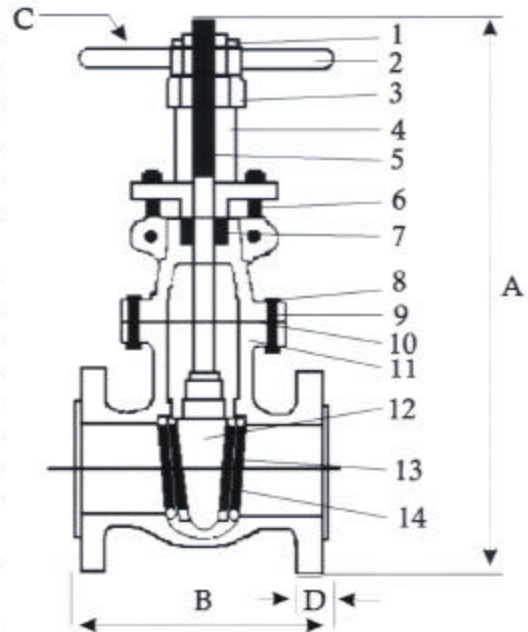

Nominal Size	Dimensions				Aprox. Weight
	A	B	C	D	
2"	17"	8 1/2"	9"	1"	60
2.5"	19 1/2"	9 1/2"	10"	1"	79
3"	20"	11 1/8"	10"	1 1/8"	104
4"	26"	12"	12"	1 1/4"	171
5"	30"	15"	16"	1 25/64"	220
6"	31"	15 7/8"	16"	1 29/64"	297
8"	41"	16 1/2"	18"	1 5/8"	434
10"	50"	18"	18"	2"	540